



Ladder-Lift Assembly and Operating Instructions

Conveying & Hoisting Solutions Pty Ltd
 ABN 78 163 105 744

1.

1. Purpose of Equipment

Ladder-Lifts are intended for the carriage of materials within the specifications of the equipment as described below.

Ladder-Lifts are **not** intended for the carriage of humans or animals.

Safety

2.1 Warnings

2. Read and understand these instructions first before setting up or operating this equipment.
3. Keep these instructions accessible near the Ladder-Lift.
4. Before beginning work, one should become familiar with the working environment and correct any hazards.
5. No changes, additions or modifications may be made to the Ladder-Lift or associated equipment.
6. Do not modify, remove, bypass or override the safety devices.
7. Do not use the Ladder-Lift if there is any damage or unusual performance. Isolate the Ladder-Lift as described in Chapter 7.1 Emergency Shutdown.
8. Do not erect or use a Ladder-Lift where the Ladder or it's load is within 3m from 240v or 415v powerlines.
9. Ladder-Lifts **must** be secured at the top of the tracks to a structure capable of withstanding a force of 2kN. Securing the base track section is recommended.
10. Do not operate the Ladder-Lift if there is a risk of people being endangered by the load or load carrying devices. Have the area around the Ladder-Lift barricaded off and post warning notices.
 - Observe National Plant Regulations and Occupational Health and Safety Regulations.
 - Do not step over or onto the Ladder-Lift.

2.2 Risk Assessment

Please note that this checklist is indicative only. Users must perform their own Risk Assessment subject to the intended siting and use of the equipment.

Hazard	Risk	Control
Crushing by the Ladder-Lift collapsing, tipping or rolling	Moderate	<ul style="list-style-type: none"> • Barricade a work-space with a radius equal to the track length during assembly and ensure the Ladder-Lift is raised using safe work practices. • Ensure attachment/securing structure is of adequate strength and the Ladder-Lift is correctly attached. • Assemble and operate on firm level ground only. • Assemble as per instructions and good rigging practices. • Do not overload the Ladder-Lift. • Wire rope must be neatly wrapped on the winch drum at all times.
Crushing or shearing by trapping between the Ladder-Lift and fixed structures	Moderate	<ul style="list-style-type: none"> • Do not stand underneath or at the bottom of the Ladder-Lift. • Have the area around the Ladder-Lift barricaded to exclude unauthorised personnel.
Falling when unloading a raised carrier	Moderate	<ul style="list-style-type: none"> • Barricade area at height to prevent falls. • Use height safety equipment.
Electrocution	Moderate	<ul style="list-style-type: none"> • Ensure the Ladder-Lift and load are not 3m or less from 240v or 415v power lines. Read and understand the "NO-GO" regulations.
Striking or crushing by materials falling from the equipment	Low	<ul style="list-style-type: none"> • Ensure the correct carrier is used. • Do not overload the carrier. • Any loose or suspect materials should be adequately secured before hoisting.

Hazard (cont'd)	Risk	Control
Crushing or entanglement when inspecting or maintaining the Ladder-Lift	Low	<ul style="list-style-type: none"> When inspecting the wire rope or correcting the wire rope wrap, take care not to place body or clothing parts within 300mm from the wire rope drum. Do not place body parts against the Ladder-Lift when in operation.
Electrocution	Moderate	<ul style="list-style-type: none"> Use an E.L.C.B., an R.C.D. or other "safety switch" in the power supply. Do not allow the Hoist or load to enter the NO GO Zone for Power Lines. Prevent moisture from coming into contact with leads and plugs. Do not alter or tamper with electrical parts.
Explosion	Low	<ul style="list-style-type: none"> Before use, ensure there are no explosive substances present near the Hoist.

2.3 Certification

Certification to operate this equipment is not required, but the Operator must be at least 18 years old and be assessed for competency by the person with management or control of the workplace. Non-certified Operator training is available at any Conveying and Hoisting Solutions depot.

2.4 Incident Notification

The employer, as defined by the Regulations referred to below, who has management or control of the workplace must be aware that they may have an obligation to notify WorkCover of any incidents involving this equipment. Refer to the Occupational Health and Safety Act and the Occupational Health & Safety (Incident Notification) Regulation(s) applicable in your State.

2.5 Inspections

Inspections as detailed in Chapter 6: Maintenance should be performed before Installation or Use of this equipment.

3 Specifications

3.1 Performance

- Load capacity: 150kg/200kg depending on type of sections supplied
- Lifting speed: 25m/min
- Power supply: 240v 50Hz 1kW maximum lead length 20m 3 x 2.5mm² construction
- Maximum track length: 19m
- Wire rope: 5mm 6x19 fibre core G1570 42m max length
- Angle of incline: see table below (minimum 20° incline with supports every 1 metre including joins when used as an inclined railway).

3.2 Masses

- 88kg (Winch, standard trolley, 2m base section and head section)
- 2m ladder section 10kg
- 1m ladder section 5.5kg
- Variable/Tile/Tipping platforms 34kg
- sheet carrier 40kg; furniture platform 51kg
- Tipping Trolley 45kg

4 Load Chart

Length/angle	Without Support			With Support				
	70°	60°	50°	40°	70°	60°	50°	40°
5m	150	150	150	150	150	150	150	150
7m	150	150	120	100	150	150	150	150
9m	150	120	90	75	150	150	150	150
11m	135	100	75	60	150	150	135	120
13m	115	80	60	50	150	130	105	90
15m	-	-	-	-	135	100	80	70
17m	-	-	-	-	120	90	70	60
19m	-	-	-	-	100	75	60	50

Note: Supports must be placed at intervals of 7m or less

5 Carrier Use

Use	Carrier
General Materials	<ul style="list-style-type: none"> • Universal Carrier with adjustable legs. • Tile Carrier with hinged covers. • Rubbish Box. • Furniture Carrier. • Non-Tipping Skip. • Tipping Skip.
Tiles	<ul style="list-style-type: none"> • Tile Carrier with hinged covers. • Universal Carrier with adjustable legs.
Soil	<ul style="list-style-type: none"> • Tipping Skip
Concrete / Mortar	<ul style="list-style-type: none"> • Tipping Skip • Universal Carrier with adjustable legs.

6 Description

6.1 General

Ladder Lifts are made up to length using a Base, Head with 2m and 1m Sections as required. Bend sections are used where variable slopes are required, such as in roofing tile work. Props are used to prevent sag.

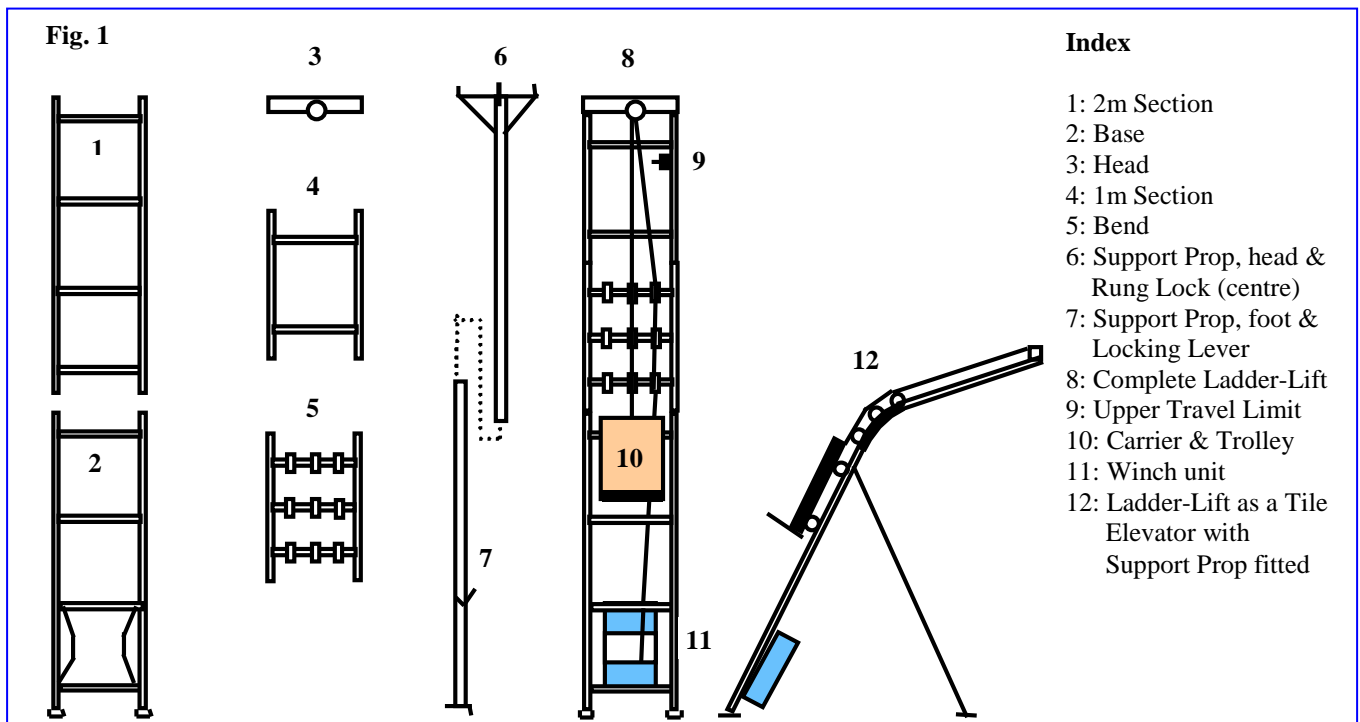

6.2 Hand Controls

Hand Controls are used to control the motion of the Ladder-Lift. Hand Controls are connected to the rear of the Winch by a 4 pin white plug. Controls fitted with an EMERGENCY STOP button use a 5 pin plug.

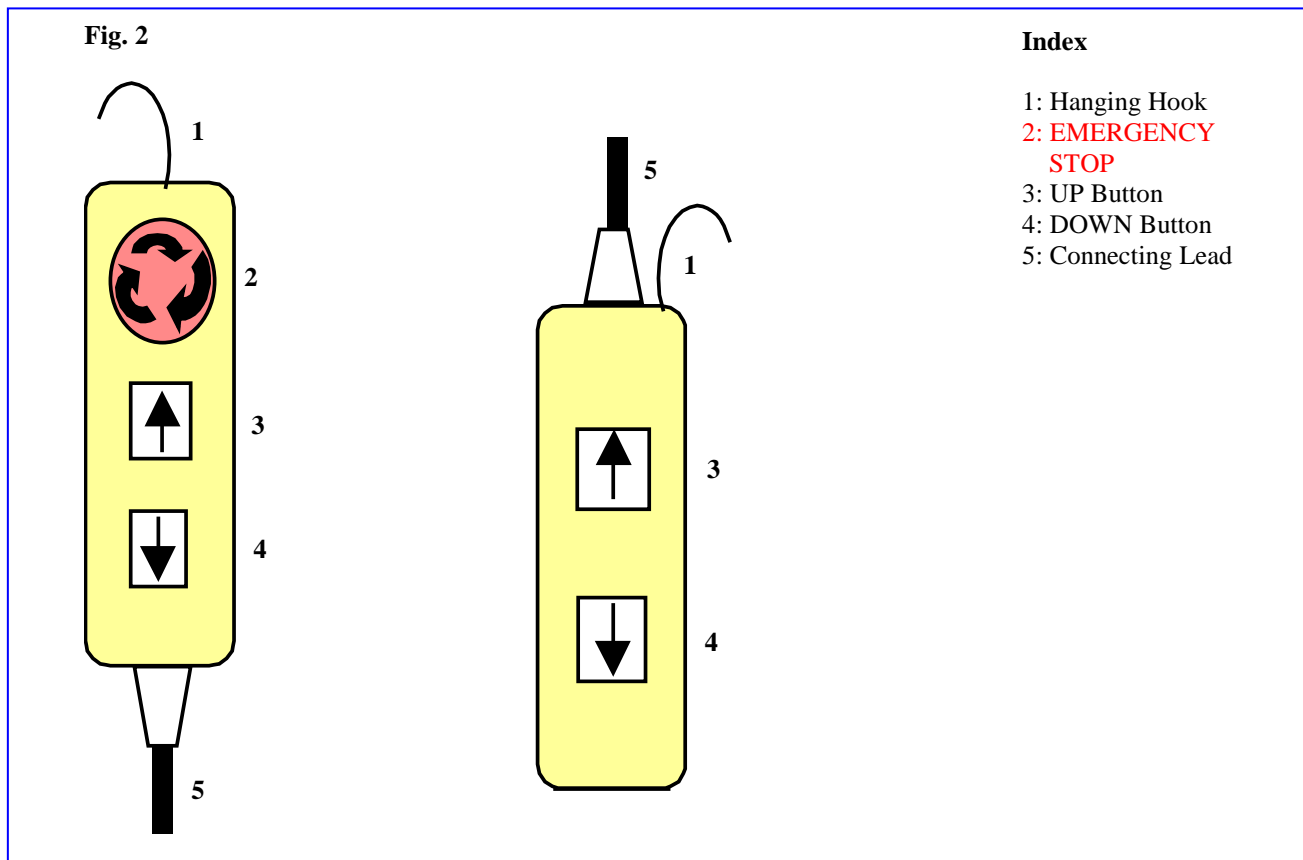

6.3 Travel Limit Switches

A Travel Limit Switch is fitted at the top of the Ladder-Lift to stop upward motion. This prevents the trolley from hitting the Head section and also limits the tipping range of a Tipping Trolley. A Bottom Travel Limit Switch, as part of the Winch unit, switches off the Ladder-Lift when the wire rope goes slack.

The Upper Travel Limit Switch, clamped with the eye nut, is positioned on the right-hand side of the Ladder-Lift.

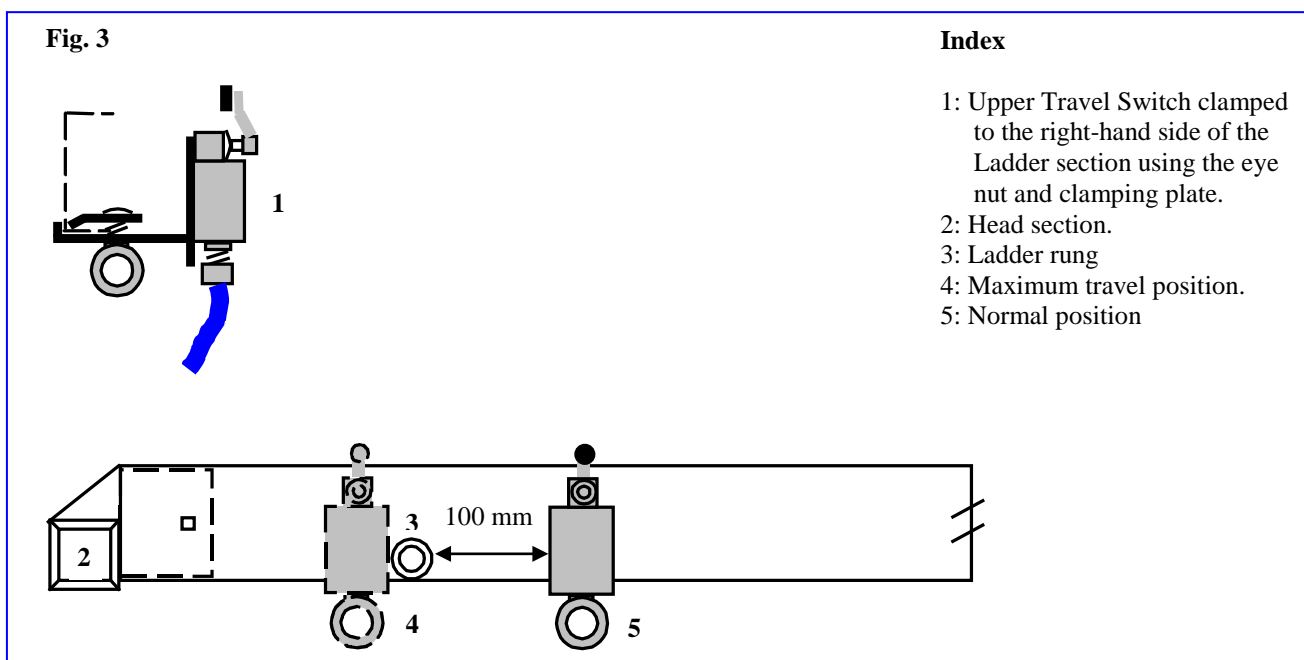

6.4 Safety Brake

A Safety Brake is fitted to all Trolleys to prevent the downward fall of the trolley and the attached carrier in the unlikely event of wire rope or other lifting component failure. Safety Brakes may engage if the angle of incline is insufficient.

Fig. 4

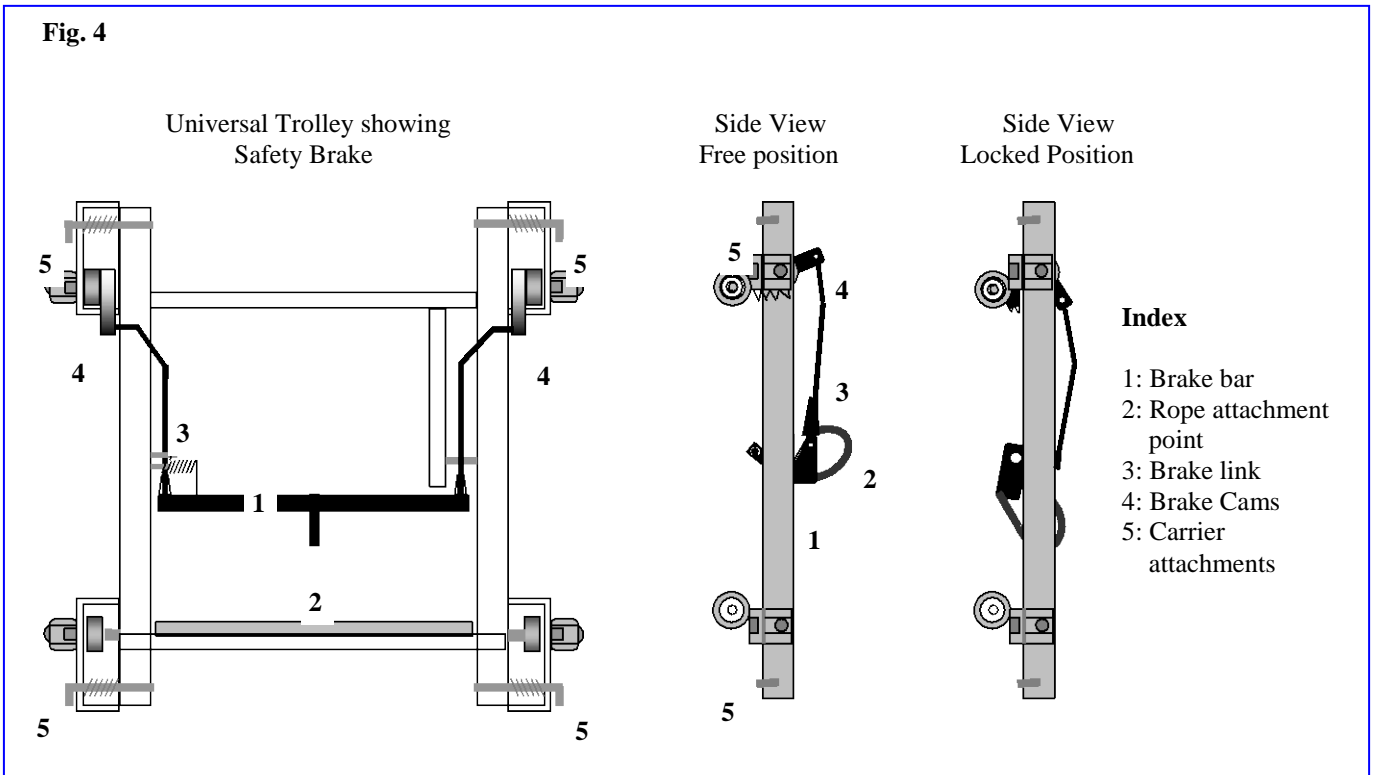

6.5 Carriers

Carriers are attached to the trolley by 4 spring-loaded pins on the trolley.

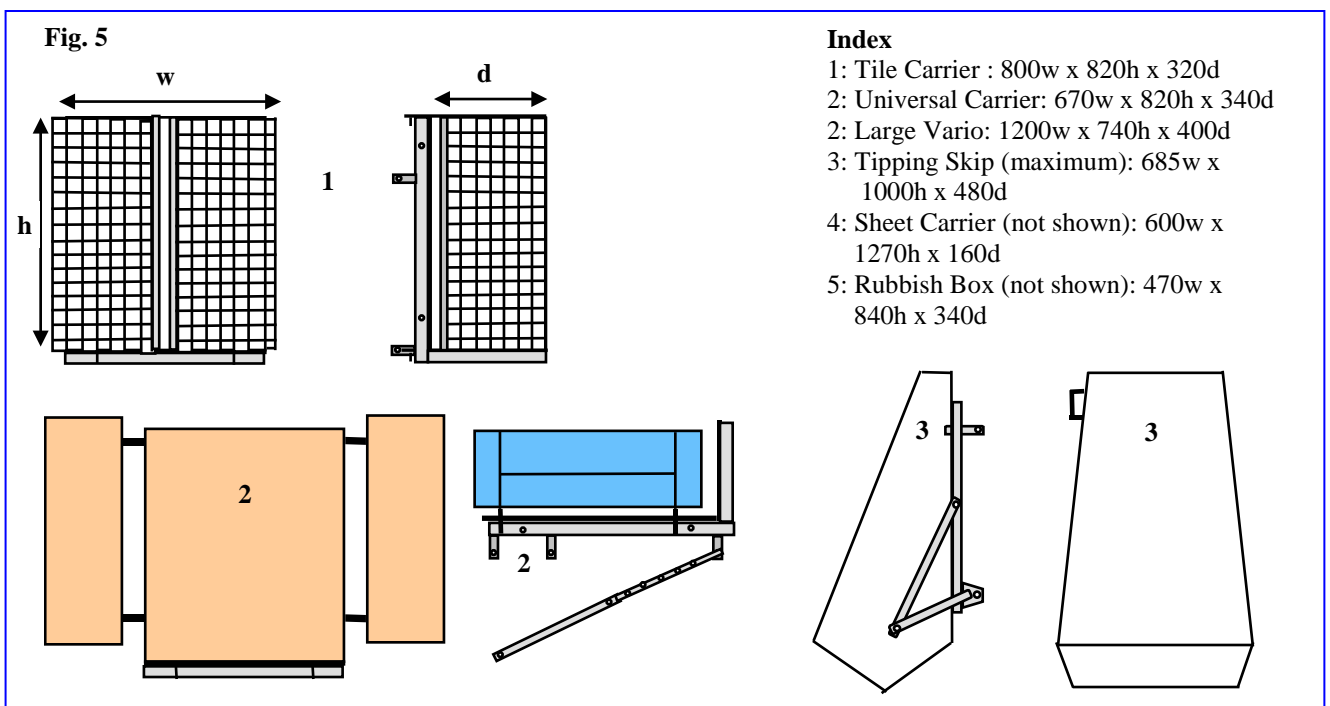

7 Operation

7.1 Pre-operation

- Read and understand the warnings given in Chapter 2.1
- Conduct a Risk Assessment as outlined in Chapter 2.2
- Ensure that the required maintenance as described in Chapter 6, has been performed before operation.
- Ensure that the operator is familiar with the equipment, its controls and operation.

7.2 Prohibited Operations

- Hoisting people or animals.
- Exceeding the maximum specifications of the equipment as specified in Chapter 3
- Loading one side of the carrier only.
- Working in wind speeds exceeding 70km/hr.
- Working before pre-operation checks have been performed as described in Chapter 5.1

7.3 Switching on and off

Refer to Chapter 4 for a description for the controls of this equipment

- Release the **EMERGENCY OFF** button if fitted.
- Press and hold the UP button to raise the carrier.
- Release the button to stop raising.
- Press and hold the DOWN button to lower the carrier.
- Release the button to stop lowering.
- Motion will be stopped at each end of the ladder by the Travel Limit Switches
- Pressing the **EMERGENCY OFF**, if fitted, will cause motion to stop.

8 Maintenance

8.1 Daily

- Ensure the Ladder-Lift, carrier and surrounding work area are clean.
- Check the Safety Brake as described in Chapter 6.2
- Inspect the wire rope for wear and damage. Check the fitting to the carrier is secure and is in good condition, particularly the wire rope termination.
- Ensure the wire rope is neatly wound on the winch. If not, do not proceed until the wire rope has been re-wrapped as described in Chapter 6.3
- Check there is no damage to the Ladder-Lift or its components, particularly the carrier.
- Check that the installation is still secure, and that there is no risk of the Ladder-Lift toppling or collapsing during use.
- Run the empty Ladder-Lift up to the Upper Travel Limit and then down to the Bottom Travel Limit checking for smoothness of operation, effectiveness of the Travel Limits and any unusual operation.

8.2 Checking the Safety Brake

- Refer to Fig. 4
- Ensure the Ladder-Lift is unloaded and the carrier is at the bottom.
- Have two people stand each side of the Ladder-Lift and ensure that no body parts are under any Ladder-Lift component.
- Lift the carrier and trolley up 600mm and release suddenly.
- The carrier and trolley should drop slightly and then jam on the base section.
- Should the carrier and trolley fall to the bottom of the base section, shutdown the Ladder-Lift as described in Chapter 7.1 Emergency Shutdown.
- If the carrier and trolley jam on the base section, grip the left-hand wire rope and pull until tense.
- Press the UP button on the Hand Control until the carrier raises slightly and the stop.
- Return the carrier to the bottom.
- The test has been successfully completed.
- Check that the wire rope is still neatly wound on the winch drum.

8.3 Re-wrapping the Wire Rope

- Refer to Fig. 7
- Use gloves to handle the wire rope.
- Unload the Ladder-Lift.
- Raise the carrier until the Winch is exposed.
- Hold the carrier firmly while pressing the DOWN button until the Safety Brake engages jamming the carrier on the base mast.
- Grip the wire rope where it joins the carrier trolley.
- Run out the wire rope by pulling the rope upwards and pressing the DOWN button.
- The winch will only run if the rope is tight and the roller bar assembly is not tilted engaging Down Travel Limit.
- Run out the wire rope until all loosely wrapped rope has been unwound.
- Grip the wire rope tightly and press the UP button.
- Continue winding in the wire rope until the rope is taken up to the carrier. Take care in the last 300mm that the carrier does not suddenly move upward, causing injury.

8.4 Monthly

- Perform the Daily Maintenance as described in Chapter 6.1
- Unwind the whole wire rope from the winch. Inspect the wire rope for wear, kinks, bends, stretch, birdcaging or other damage.
- Rewrap the wire rope as described in Chapter 6.3
- Lubricate the gear on left-hand side of the wire rope drum with grease.

9 Shutdown

9.1 Emergency Shutdown

- Stop operation of the Ladder-Lift by either:
 1. Releasing the UP or DOWN buttons (see Figures 2 & 3)
 2. Pressing the **EMERGENCY-OFF** button, if fitted (see Figure 2)
 3. Pulling out the hand control from the socket on the winch/motor unit (see Figure 1)
 4. Turning off the power supply.
- Remove the hand control and power supply from the Ladder-Lift.
- Secure the load hook and/or load against uncontrolled movement (wind etc).
- Erect a sign stating “DO NOT USE – HOIST UNDER REPAIR” and fix to the Ladder-Lift.
- Inform management or management’s agent of the situation.

9.2 End of Work / Hire Period Shut-down

- Unload the Ladder-Lift and raise the hook up to the Upper Travel Limit Switch.
- Remove the hand control and the power supply.
- Secure the winch/motor against unwanted movement by engaging the Slew Locking Lever on the mounting Yoke.
- Clean any dirt or grease from the Ladder-Lift.

10 Installation

10.1 Warning

- Do not connect the pendant hand control or power supply until the motor/winch has been mounted or mechanical damage may occur.
- Do not install the equipment within 3 metres of powerlines. A Spotter is required if installation is within 3m to 6m of powerlines. Call Conveying and Hoisting Solutions for details.

10.2 Pre-Installation

- Check the height of lift required, assess the angle of incline and determine from the load chart in Chapter 3.3 that the load is within the Ladder-Lift specifications.
- Calculate the length of track required.

- Where the Ladder-Lift is intended as a Tile Elevator and a Bend section will be required at the eaves, calculate the track length to the eaves only.
- Read and understand all instructions before installation, particularly Chapter 2 (Safety) and Chapter 5 (Operation)
- Barricade off a work area with a radius equal to the calculated track length. This area is required in case of the Ladder-Lift toppling during erection.
- Install the Ladder-Lift on solid, even ground. If this is impossible, use weight distribution base plates.

10.3 Installing the Ladder Sections.

- Refer to Fig. 6
1. Place the base section on the ground with the rungs on the bottom.
 2. Slide on the trolley. Non-tipping trolleys should be mounted with the Safety Brake towards the top of the Ladder-Lift. Tipping trolleys should be mounted with the catch-hook towards the top of the Ladder-Lift.
 3. Assemble 2m and/or 1m sections as required to achieve the calculated track length and fix with bolts provided, with the ring to the outside of the section.
 4. For Tile Elevator applications, insert the Bend unit and secure as described in 3).
 5. Insert the head section with the pulley guard upwards. Secure as described in 3).
 6. Stand-up the assembled Ladder-Lift using craneage, sufficient manpower or other suitable lifting techniques such as a block and tackle attached to the head. Care should be taken to ensure the safety of the personnel erecting the Ladder-Lift and other personnel in the vicinity and that the length or mass of the ladder assembly is not above the capacity of the lifting method, causing the Ladder-Lift to topple over.
 7. For Tile Elevator configurations, alter the bend angle so that the bend unit rests on the structure and takes up some of the load. Alter the bend angle by loosening the ring-nuts at the side adjusting brackets, adjust the angle and re-tighten. The bend unit has a short side and a long side and may be reversed to better fit the installation. To reverse the bend unit, remove the joining tongues and fit to the opposite end and secure. Continue adding 2m and/or 1m ladder sections on the roof slope until the desired height is reached. Assemble the head section on the last section and fix.
 8. Secure the Ladder-Lift to the structure using a suitable method such as two 12mm fibre ropes tied to the ladder section joining ring-nuts.

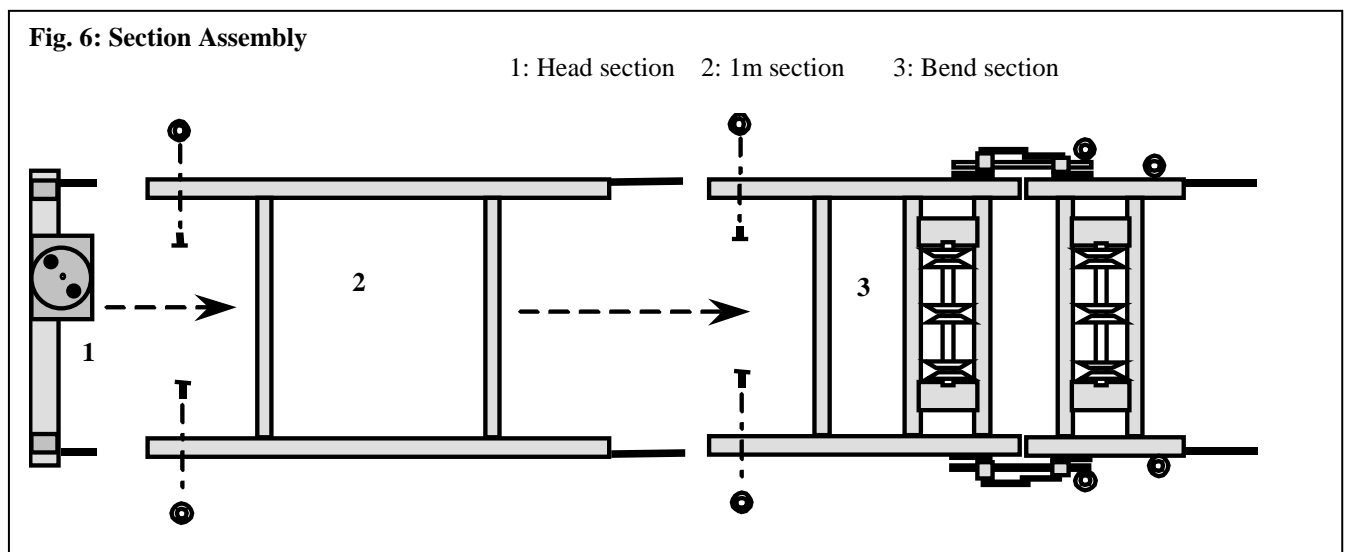

10.4 Inserting the Support Prop

- Refer to Fig.1
1. Ensure a light rope is attached to the Rung Lock on the Prop.
 2. Position the Prop approximately half-way along the Ladder-Lift assembly, or at intervals of no greater than 7m
 3. Depress the Locking Lever and slide the top part out of the bottom part until the head reaches a section rung.
 4. Pull on the light rope to open the Rung Lock and fit the two tabs on the Prop head over the section rung.
 5. Release the light rope to engage the Rung Lock. Secure the rope.
 6. Adjust the length so that the Prop supports the Ladder-Lift, but does not exert any upward pressure.
 7. Ideally, the Prop should be at approximately 80°, pointing back toward the bottom of the Ladder-Lift.

10.5 Installing the Winch

- Refer to Fig. 7
1. The motor/winch unit fits between the bottom rung and the first ring at the rear of the Ladder-Lift base section. Lift the motor/winch and place the 'U' shape recess at the underside of the motor/winch unit onto the bottom rung. Loosen the

wing nuts and lift the mounting plates, or lift up the release catches found on top of the motor/winch and place the second rung of the Ladder-Lift base section within these catches and lock down.

2. Mount the upper travel-limit switch to prevent the trolley hitting the head section. Undo the upper limit switch lead on the right-hand side of the motor/winch unit and fix the switch on the right-hand side, just before the last rung at the top of the Ladder-Lift.
3. When the winch has been mounted, plug in the yellow pendant hand control into the appropriate socket on the rear of the motor/winch unit.
4. Plug in the power supply.

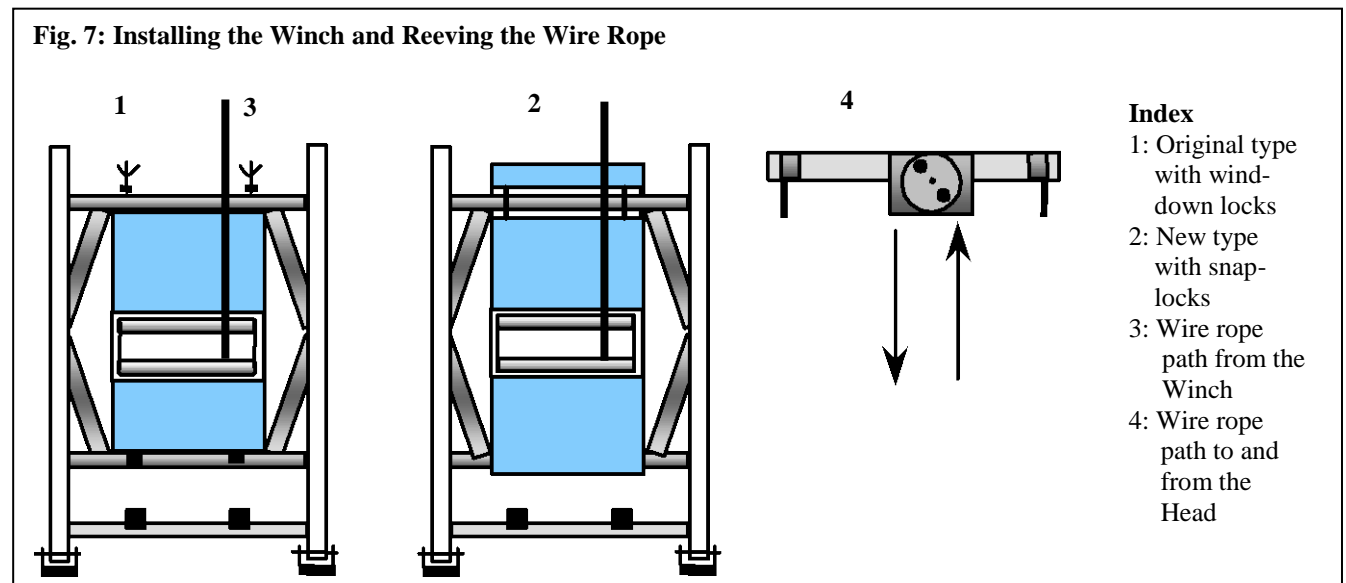

10.6 Reeving the Wire Rope

- Refer to Fig. 7
1. The wire rope is now ready to attach to the trolley. The wire rope runs on the front side of the Ladder-Lift up to the head section and then down the centre of the Ladder-Lift, to the trolley.
 2. Lift the trolley up to expose the winch front. See Chapter 6.3 for instructions.
 3. Unwind sufficient wire rope to reach up over the head section and back down to the trolley.
 4. Take the wire rope up to the head section. Open the cover over the head sheave (pulley) by pulling outwards and expose the groove in the sheave. Lay the wire rope in the groove in an **anti-clockwise** direction and close the cover. Ensure the cover does not foul the wire rope.
 5. On standard trolleys, clip the wire rope to the eye found on the movable bar. For tipping trolleys, reeve the wire rope under the rear sheave then wrap the wire rope at least 4 times around the rope drum and clip the rope end to the anchorage on the drum. Any extra rope-length at the clip end should be fed backward through the rope wound on the trolley drum until clear of the trolley.
 6. Take up slack wire rope by winding it back onto the winch drum. Hold the wire rope tightly and press the UP button, ensuring the wire rope winds neatly onto the winch drum.

10.7 Attaching the Load Carrier

1. **All Carriers:** Attach the carrier to the trolley by the 4 spring-loaded clips on the trolley.
2. **Variable and Furniture Carriers:** Adjust the legs these carriers so that the floor of the carrier runs in a horizontal plane.
3. **Tipping Skips:** Adjust the upper travel-limit switch position for tipping carriers so that they don't over-tip and fail to return.
4. **Sheet Carrier:** Raise the trolley using the Winch 400mm and then attach the Sheet Carrier. Take care that the carrier does not become wedged under the Base section.

Installation is now complete

11 Removal

Removal of the Ladder Lift is the reverse of the instructions given in Chapter 8: Installation.